

Home Gateway

5 Giga Ethernet | 2.4G 2T2R + 5G 2T2R | USB2.0

VR-3047eu

xDSL AC1200 Wireless Gateway



The VR-3047eu makes full use of its dual band Wi-Fi abilities, reaching speeds of up to 300Mbps on the 2.4GHz band and 867Mbps on the 5GHz band. Enjoy a total speed of up to 1200Mbps to eliminate buffering from your HD streams and lag from online games. The two wireless bands are separated in two dedicated Wi-Fi networks, supporting more devices while reducing signal interference, to deliver a stable connection for every wireless device in your home.

FEATURES

- **Satisfies your multiple needs in one device**
The modem router combined the function of VDSL modem, NAT router, 4-port switch and wireless access point into one fashionable device, providing one-stop solution for your home network connection.
- **Full Gigabit Wired Connections for Ultrafast Data Transfer Speeds**
With one Gigabit WAN port and four Gigabit LAN ports, speeds can be up to 10× faster than standard Ethernet connections.
- **Versatile USB Sharing**
With the USB 2.0 port, you can share printers, files, and media with various devices on your local network or via FTP server.

VR-3047eu

5 Giga Ethernet | 2.4G 2T2R + 5G 2T2R | USB2.0

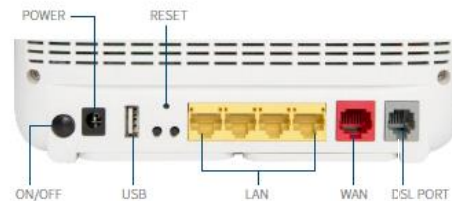

SPECIFICATIONS

Hardware

- Chipset: RTL8685FB (CPU) + RTL8275-VS (AFE) + RTL8192FR-CG (2.4GHz) + RTL8812FR-CG (5GHz)
- Interfaces: 1 x DSL Port, 1 x 10/100/1000Mbps WAN Port, 4 x 10/100/1000Mbps LAN Ports, 1 x USB2.0
- Power Supply: DC 12V 1.5A
- Memory: 16MB FLASH / 128MB DRAM (embedded)
- Antenna: 4x internal antennas
- Dimensions (WxDxH): 186x151x30mm

General

- DSL Standards: VDSL2, ADSL2/2+, ADSL
- Wireless Standards: IEEE802.11a/n/ac,5GHz, IEEE802.11b/g/n,2.4GHz
- Signal Rate: 5GHz: Up to 876Mbps, 2.4GHz: Up to 300Mbps
- Operation Frequency: 2.4GHz & 5GHz
- Reception Sensitivity:
5GHz:
11a 6Mbps: -96dBm, 11a 54Mbps: -79dBm
11ac HT20: -71dBm, 11ac HT40: -66dBm, 11ac HT80: -63dBm,
11n HT20: -72dBm, 11n HT40: -71dBm
2.4GHz:
11g 54M: -77dBm
11n HT20: -74dBm, 11n HT40: -72dBm
- Wireless Security: WEP, WPA / WPA2, WPA-PSK / WPA2-PSK encryption

Software Features

- WAN Type: ATM/PTM/ETH/Dongle
- DHCP: Server, Client, DHCP Client List, Address Reservation
- Quality of Service: WMM, Bandwidth Control
- Port Forwarding: Virtual Server, Port Triggering, UPnP, DMZ
- VPN Pass-Through: PPTP, L2TP, IPsec
- Access Control: Parental Control, Local Management Control, Host List, Access Schedule, Rule anagement
- Firewall Security: DoS, SPI Firewall, IP Address Filter / MAC Address Filter / Domain Filter, IP and MAC Address Binding
- USB Sharing: Support Samba (Storage) / FTP Server, Media Server / Printer Server / DLNA
- Management: Access Control, Local Management, Remote Management
- Internet Protocol: IPv4, IPv6

Environment

- Operating Temperature: 0°C~40°C (32°F~104°F)
- Storage Temperature: -40°C~70°C (-40°F~158°F)
- Relative Humidity: 10%~90%, non-condensing
- Storage Humidity: 5%~90%, non-condensing

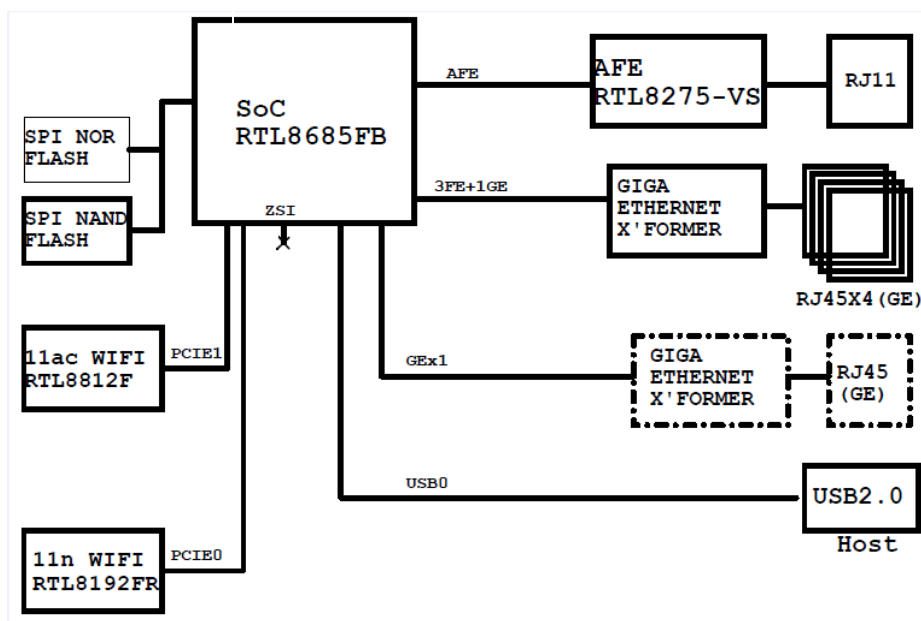

COMTREND

Taiwan:
3F-1, No.10, Lane 609, Chongxin Road, Section 5,
Sanzhong Dist, New Taipei City 241405, Taiwan
Tel: 886-2-2999-8261
Fax: 886-2-2999-8497

USA & Canada:
530 Technology Dr. Suite 100 Irvine,
CA 92618, USA
Tel: 1-949-753-9640
Fax: 1-949-753-9020

Spain:
Edif. América II C/Prócion,7 portal 3 bajo H 28023
Madrid, Spain
Tel: 34-917990403
Fax: 34-913510999

Czech Republic:
TOKOVO Jankovcova 1518/2, 170 00, Prague 7,
Czech Republic
Tel: 420-266-782040
Fax: 420-266-782990